

# SELF-PROPELLED SCISSOR LIFTS

## GS™-1530 & GS™-1930



## Specifications

MODELS	GS™-1530		GS™-1930	
	US	Metric	US	Metric
Working height maximum*	21 ft	6.57 m	25 ft	7.79 m
<b>A</b> Platform height maximum	15 ft	4.57 m	19 ft	5.79 m
<b>B</b> Platform height stowed	3 ft 2.2 in	.97 m	3 ft 3.5 in	1.00 m
<b>C</b> Platform length - outside	5 ft 4 in	1.63 m	5 ft 4 in	1.63 m
extended	8 ft 4 in	2.54 m	8 ft 4 in	2.54 m
Slide-out platform extension deck	3 ft	.91 m	3 ft	.91 m
<b>D</b> Platform width - outside	2 ft 5 in	.74 m	2 ft 5 in	.74 m
Guardrail height: fixed rails	3 ft 3 in	.99 m	3 ft 3 in	.99 m
fold down (CE)	3 ft 7 in	1.10 m	3 ft 7 in	1.10 m
Toeboard height	6 in	.15 m	6 in	.15 m
<b>E</b> Height - stowed: fixed rails	6 ft 5 in	1.96 m	6 ft 7 in	2.00 m
folding guardrails (CE)	6 ft 8 in	2.03 m	6 ft 11 in	2.11 m
rails folded	5 ft 8 in	1.73 m	5 ft 9 in	1.75 m
<b>F</b> Length - stowed	6 ft	1.83 m	6 ft	1.83 m
Length - stowed extended	9 ft	2.74 m	9 ft	2.74 m
<b>G</b> Width	2 ft 6 in	.76 m	2 ft 6 in	.76 m
<b>H</b> Wheelbase	4 ft 4 in	1.32 m	4 ft 4 in	1.32 m
<b>I</b> Ground clearance - center	2.4 in	.06 m	2.4 in	.06 m
<b>J</b> - with pothole guards deployed	.75 in	.02 m	.75 in	.02 m

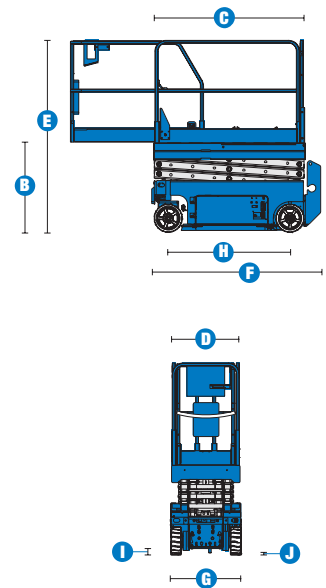

PRODUCTIVITY				
Maximum platform occupancy**	2	2	2	2
Lift capacity	600 lbs	272 kg	500 lbs	227 kg
Lift capacity - extension deck	250 lbs	113 kg	250 lbs	113 kg
Drive speed - stowed	2.5 mph	4.0 km/h	2.5 mph	4.0 km/h
Drive speed - raised	0.5 mph	0.8 km/h	0.5 mph	0.8 km/h
Gradeability - stowed***	30%		30%	
Turning radius - inside	zero	zero	zero	zero
Turning radius - outside	5 ft 1 in	1.55 m	5 ft 1 in	1.55 m
Raise / lower speed	16 / 29 sec	16 / 29 sec	16 / 25 sec	16 / 25 sec
Controls	proportional		proportional	
Drive	dual front wheel		dual front wheel	
Multiple disc brakes	dual rear wheel		dual rear wheel	
Tires - solid non-marking	12 x 4.5 x 8 in	30 x 11 x 20 cm	12 x 4.5 x 8 in	30 x 11 x 20 cm

POWER				
Power source	24 V DC (four 6 V 225 Ah batteries)		24 V DC (four 6 V 225 Ah batteries)	
Hydraulic system capacity	3.75 gal	14.2 L	3.75 gal	14.2 L

WEIGHT****				
ANSI, CSA	2,575 lbs	1,168 kg	2,702 lbs	1,226 kg
CE indoor	2,718 lbs	1,233 kg	3,302 lbs	1,498 kg
AUS indoor	—	—	3,302 lbs	1,498 kg

STANDARDS COMPLIANCE	ANSI A92.6, CSA B354.2, CE Compliance, AS 1418.10
----------------------	---

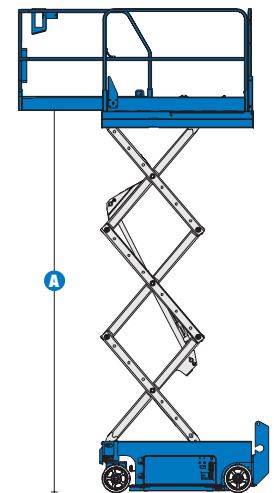

\* The metric equivalent of working height adds 2 m to platform height. U.S. adds 6 ft to platform height.  
 \*\* CE/AUS markets: GS-1530 and GS-1930 are indoor use only—2 person maximum occupancy.  
 GS-1532 and GS-1932 are indoor/outdoor use—1 person maximum.  
 \*\*\* Gradeability applies to driving on slopes, see operator's manual for details regarding slope ratings.  
 \*\*\*\* Weight will vary depending on options and/or country standards.

[www.genieindustries.com](http://www.genieindustries.com)

## Features

### STANDARD FEATURES

#### MEASUREMENTS

##### GS™-1530

- 21 ft (6.57 m) working height
- Up to 600 lb (272 kg) lift capacity

##### GS™-1930

- 25 ft (7.79 m) working height
- Up to 500 lb (227 kg) lift capacity

#### PRODUCTIVITY

- 64 x 29 in (1.63 x .74 m) steel platform
- Fixed rail with chain entry gate
- Folding rails with half-height swing gate (CE)
- 36 in (.91 m) extension deck
- Dual front wheel drive
- Proportional lift and drive
- Universal 20 amp smart charger
- 30% gradeability
- Platform control with battery charge indicator and diagnostic display
- AC power to platform
- Manual platform lowering valve
- Emergency stop at both platform and ground controls
- Rear wheel multiple disc brakes
- Front wheel hydraulic dynamic braking
- Brake release
- Solid non-marking tires
- Pothole guards
- Tilt level sensor with audible alarm
- Descent alarm
- Electronic horn
- Hour meter

#### POWER

- 24 V DC (four 6 V 225 Ah batteries)

### OPTIONS & ACCESSORIES

#### PRODUCTIVITY

- Folding rails with half-height swing gate
- Platform swing gate, half-height
- Air line to platform
- Dual flashing beacons
- Motion package
- Platform work lights
- Panel mounted, recessed charger receptacle
- Automotive horn

#### POWER

- Power inverter (not available GS-1930, GS-1932 CE)
- Maintenance-free batteries
- EE rating

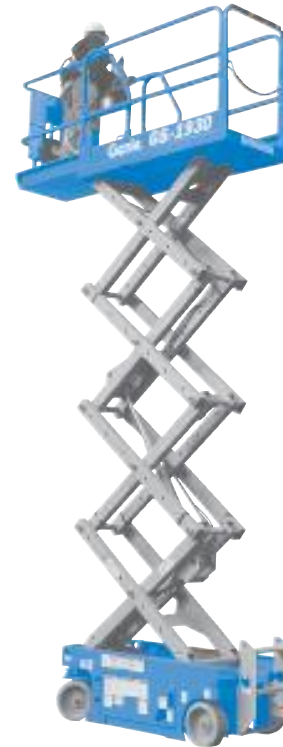

### Genie United States

18340 NE 76th Street  
P.O. Box 97030  
Redmond, Washington 98073-9730

Telephone **+1 (425) 881-1800**  
Toll Free in USA/Canada **+1 (800)-536-1800**  
Fax +1 (425) 883-3475

### Genie Europe

Millennium House  
Brunel Drive  
Newark NG24 2DE  
UK

Telephone **+44 (0)1476 584333**  
Fax +44 (0)1476 584334

Email: [infoeurope@genieind.com](mailto:infoeurope@genieind.com)

### Distributed By:

Effective Date: January, 2009. Product specifications and prices are subject to change without notice or obligation. The photographs and/or drawings in this document are for illustrative purposes only. Refer to the appropriate Operator's Manual for instructions on the proper use of this equipment. Failure to follow the appropriate Operator's Manual when using our equipment or to otherwise act irresponsibly may result in serious injury or death. The only warranty applicable to our equipment is the standard written warranty applicable to the particular product and sale and we make no other warranty, express or implied. Products and services listed may be trademarks, service marks or trade-names of Terex Corporation, Genie Industries, Inc. and/or their subsidiaries in the U.S.A. and many other countries and all rights are reserved. Terex is a Registered Trademark of Terex Corporation in the U.S.A. and many other countries. Genie is a Registered Trademark of Genie Industries, Inc. in the U.S.A. and many other countries. Genie is a Terex Company. © 2009 Terex Corporation.

GS30 3.5K 0109K. Part No. 109377

[www.genieindustries.com](http://www.genieindustries.com)